

BS9892
STEERING TUBE BEARING PULLER



RELEVANT PRODUCTS OF STEERING
HEAD BEARING SERVICE



BS9893
Steering Tube Bearing
Installer Tool Set

APO TOOL INTERNATIONAL LTD.
No.38 Ping An St, Changhua, Taiwan 50055
T: +886 4 7514888 / F: +886 4 7524888
Website : www.bikeservice.com.tw
E-mail : service@bikeservice.com.tw

Represent.

PRODUCT FEATURE

BikeService BS9892 Use this tool to remove the lower fork stem(Separator) tapered bearing.
Tapered fork stem bearing removal,it features extra thin opening with 15 degree rim for slot entrance between stem and bearing, extend rod can be used on multiple size of fork stems.

BS9892
STEERING TUBE BEARING PULLER



RELEVANT PRODUCTS OF STEERING
HEAD BEARING SERVICE



BS9893
Steering Tube Bearing
Installer Tool Set

APO TOOL INTERNATIONAL LTD.
No.38 Ping An St, Changhua, Taiwan 50055
T: +886 4 7514888 / F: +886 4 7524888
Website : www.bikeservice.com.tw
E-mail : service@bikeservice.com.tw

Represent.

PRODUCT FEATURE

BikeService BS9892 Use this tool to remove the lower fork stem(Separator) tapered bearing.
Tapered fork stem bearing removal,it features extra thin opening with 15 degree rim for slot entrance between stem and bearing, extend rod can be used on multiple size of fork stems.

COMPONENT IDENTIFICATION



Contents:

- A** Ø30~56mm Bearing Separator
- B** 2pc (L) 240~320mm Extension Bar
- C** (L) 100mm Forcing Screw
- D** Ø30mm Tip
- E** 45~100mm Beam
- F** 17mm and 19mm Ratchet Wrench
- G** 2pc M8 x (L) 80mm Separator Bolt and Nut

TAP STEERING HEAD BEARING STEPS

1. Please adjust the space of Bearing Separator (A) according to the size of the replacement bearing. Or use 2PC M8 x 80mm Separator Bolt and Nut (G) to operate.
2. Assemble Bearing Separator (A) into the space of Single-row tapered roller bearing and Lower triple clamp. Use Ratchet Wrench (F) 17mm to fix M10xp1.25x50 Screw of the Bearing Separator.
3. Finish the assembly of the spare components. Please find Fig 2 for reference.
4. Use Ratchet Wrench (F) 19mm, set into Forcing Screw (C) which end of hex. Rotate in a clockwise direction. Drive Bearing Separator (A) upwards to disassemble the bearing. Please find Fig 3 for reference.

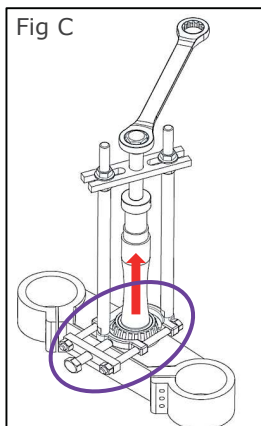
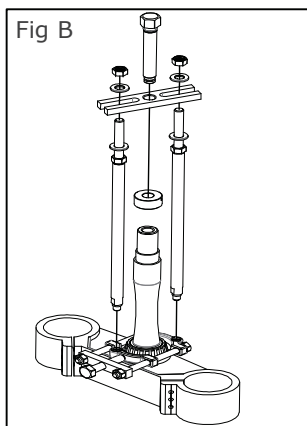
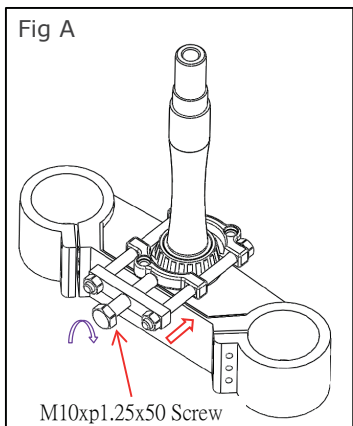

COMPONENT IDENTIFICATION



Contents:

- A** Ø30~56mm Bearing Separator
- B** 2pc (L) 240~320mm Extension Bar
- C** (L) 100mm Forcing Screw
- D** Ø30mm Tip
- E** 45~100mm Beam
- F** 17mm and 19mm Ratchet Wrench
- G** 2pc M8 x (L) 80mm Separator Bolt and Nut

TAP STEERING HEAD BEARING STEPS

1. Please adjust the space of Bearing Separator (A) according to the size of the replacement bearing. Or use 2PC M8 x 80mm Separator Bolt and Nut (G) to operate.
2. Assemble Bearing Separator (A) into the space of Single-row tapered roller bearing and Lower triple clamp. Use Ratchet Wrench (F) 17mm to fix M10xp1.25x50 Screw of the Bearing Separator.
3. Finish the assembly of the spare components. Please find Fig 2 for reference.
4. Use Ratchet Wrench (F) 19mm, set into Forcing Screw (C) which end of hex. Rotate in a clockwise direction. Drive Bearing Separator (A) upwards to disassemble the bearing. Please find Fig 3 for reference.

